

CS 1000X

OPERATING GUIDE



.A.



A Intended to alert the user to the presence of uninsulated “dangerous voltage” within the product’s enclosure that may be of sufficient magnitude to constitute a risk of electric shock to persons.

A Intended to alert the user of the presence of important operating and maintenance (servicing) instructions in the literature accompanying the product.

CAUTION: Risk of electrical shock – DO NOT OPEN!

CAUTION: To reduce the risk of electric shock, do not remove cover. No user serviceable parts inside. Refer servicing to qualified service personnel.

WARNING: To prevent electrical shock or fire hazard, do not expose this appliance to rain or moisture. Before using this appliance, read the operating guide for further warnings.

A Este simbolo tiene el propósito de alertar al usuario de la presencia de “(voltaje) peligroso” que no tiene aislamiento dentro de la caja del producto que puede tener una magnitud suficiente como para constituir riesgo de corrientazo.

A Este simbolo tiene el propósito de alertar al usuario de la presencia de instrucciones importantes sobre la operación y mantenimiento en la literatura que viene con el producto.

PRECAUCION: Riesgo de corrientazo – No abra.

PRECAUCION: Para disminuir el riesgo de corrientazo, no abra la cubierta. No hay piezas adentro que el usuario pueda reparar. Deje todo mantenimiento a los técnicos calificados.

ADVERTENCIA: Para evitar corrientazos o peligro de incendio, no deje expuesto a la lluvia o humedad este aparato. Antes de usar este aparato, lea más advertencias en la guía de operación.

A Ce symbole est utilisé pour indiquer à l'utilisateur la présence à l'intérieur de ce produit de tension non-isolée dangereuse pouvant être d'intensité suffisante pour constituer un risque de choc électrique.

A Ce symbole est utilisé pour indiquer à l'utilisateur qu'il ou qu'elle trouvera d'importantes instructions sur l'utilisation et l'entretien (service) de l'appareil dans la littérature accompagnant le produit.

ATTENTION: Risques de choc électrique – NE PAS OUVRIR!

ATTENTION: Afin de réduire le risque de choc électrique, ne pas enlever le couvercle. Il ne se trouve à l'intérieur aucune pièce pouvant être réparée par l'utilisateur. Confier l'entretien à un personnel qualifié.

AVERTISSEMENT: Afin de prévenir les risques de décharge électrique ou de feu, n'exposez pas cet appareil à la pluie ou à l'humidité. Avant d'utiliser cet appareil, lisez les avertissements supplémentaires situés dans le guide.

A Dieses Symbol soll den Anwender vor unisolierten gefährlichen Spannungen innerhalb des Gehäuses warnen, die von Ausreichender Stärke sind, um einen elektrischen Schlag verursachen zu können.

A Dieses Symbol soll den Benutzer auf wichtige Instruktionen in der Bedienungsanleitung aufmerksam machen, die Handhabung und Wartung des Produkts betreffen.

VORSICHT: Risiko – Elektrischer Schlag! Nicht öffnen!

VORSICHT: Um das Risiko eines elektrischen Schlages zu vermeiden, nicht die Abdeckung entfernen. Es befinden sich keine Teile darin, die vom Anwender repariert werden könnten. Reparaturen nur von qualifiziertem Fachpersonal durchführen lassen.

ACHTUNG: Um einen elektrischen Schlag oder Feuergefahr zu vermeiden, sollte dieses Gerät nicht dem Regen oder Feuchtigkeit ausgesetzt werden. Vor Inbetriebnahme unbedingt die Bedienungsanleitung lesen.

A

WARNING!

For optimum performance and reliability DO NOT PRESENT THE AMPLIFIER WITH A SPEAKER LOAD OF LESS THAN 2 OHMS, OR A COMBINATION OF SPEAKERS THAT TOGETHER ARE LESS THAN 2 OHMS!

Using one speaker, it must be rated at 2 ohms minimum.

Using two speakers, they must be rated each at 4 ohms minimum.

Using three speakers, they must be rated each at 8 ohms minimum.

The world-famous CS[®] 1000 power amplifier has been changed to the new, extended-performance CS[®] 1000X. This upgraded model provides impressive 2-ohm output power capability while still maintaining the current 4- and 8-ohm ratings, and meets rigid industry standards for power bandwidth, slew rate, and distortion specifications.

The new extended specs are:

525 W RMS into 4 ohms / 750 W RMS into 2 ohms (per channel)

1050 W RMS into 8 ohms / 1500 W RMS into 4 ohms (bridged)

DDT[™] compression with LED indicators and defeat switch

Slew Rate: 40 V/microsecond, stereo mode, each channel

Power Bandwidth: 10 Hz to 50 kHz @ 4 ohms, rated power

Total Harmonic Distortion: less than 0.03%, rated power

Hum and Noise: 100 dB below rated power, unweighted

All the current features of the previous units have been retained, including Peavey's patented DDT[™] compression system and the very flexible back-panel patching capabilities. The two-speed fan cooling system has been improved to automatically provide additional cooling for the two-ohm load conditions.

FEATURES

- Automatic two-speed fan cooling system/tunnel
- Independent channel thermal/fault protection
- Transient-free turn-on/off operation (relay)
- Two "back-porch" crossover "island" sockets for plug-in modules
- Two "back-porch" balanced-input transformer sockets for PL-2's
- Single XLR and dual phone plug inputs each channel
- XLR input can be transformer-balanced
- Dual phone plug and 5-way binding post outputs each channel
- High temperature shutdown LED each channel
- DDT[™] activation LED each channel
- ⌘ Ten-segment, tri-colored power level LED array each channel
- ⌘ Calibrated/detented input attenuator control each channel
- ⌘ Rear panel DDT[™] defeat and bridge mode select slide switches

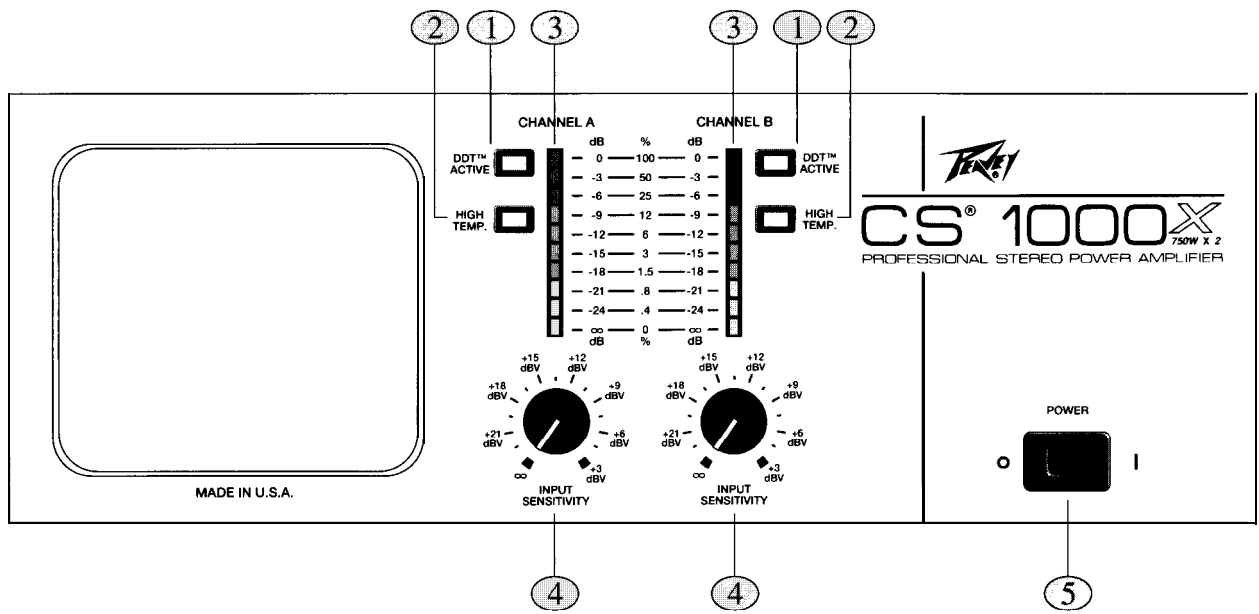

DDT™ ACTIVE LEDs (1)

The DDT™ active LEDs indicate when compression is taking place. As long as gain reduction is occurring, the LED will continue to light, thereby giving a valuable indication of this unique compression function. The DDT function can be defeated on both channels simultaneously by selecting the defeat position on the DDT compression switch (7) located on the back panel of the CS 1000X. When the compressor is defeated, the DDT active LED will indicate clipping, this being the condition where the amp is failing to faithfully reproduce the input signal. A more thorough discussion of the DDT function is included later in this manual.

HIGH TEMPERATURE LEDs (2)

These LEDs illuminate whenever the thermal logic system has determined that a particular channel is operating above safe temperature limits and has shut down the unsafe channel. When this LED is illuminated, the "0" LED will also go out on that channel. Excessive temperature conditions can occur in the CS 1000X if either or both channels are continuously operated into less than 2-ohm loads (or a short circuit), or if the ambient temperature of the air supply becomes too hot to provide adequate cooling even under normal 2-ohm or greater loading situations. Since the CS 1000X is a "redundant" amplifier, the shutdown of one channel will not affect the operation of the other channel. When the unsafe channel has cooled down to safe limits, operation will be restored in that channel. Normal operation is indicated when the high temperature LED is off and the "0" LED is on. Continued operation under fault conditions will not harm the amplifier, but because of the nuisance factor, steps should be taken to determine the problem and solve it.

LED ARRAYS (3)

The CS 1000X has a tri-colored LED array on each channel to indicate the output power level. The LED array is calibrated in two different ways to offer maximum flexibility and ease of use. In the center of the LED ladder, the calibration is percent of full power output. The top LED, labeled 100%, will flash when the CS 1000X has reached full RMS power output capability on that particular channel. Operation at power output levels below 100% will naturally be indicated by lower LED readings. The lowest value indicated is 0.4% of full power, which corresponds to 2.0 watts RMS output into 4 ohms. Operation below that power level will not be indicated, since the lowest LED is calibrated at 0% or standby. As mentioned, this LED should be illuminated whenever the amplifier is operating with AC mains power applied under zero signal

conditions. Next to each ladder the calibration is "dB below full power." This is a convenient scale that indicates the amount of power amp headroom left for any signal condition.

INPUT SENSITIVITY CONTROLS (4)

The CS 1000X features a 31 detent, calibrated sensitivity control for each channel. Each control is labeled to show the actual input sensitivity ratings of the amplifier for various settings in decibel volts necessary to attain the full-output power rating. Thus, maximum input gain (minimum sensitivity rating) is achieved at the full clockwise setting, and this setting yields maximum mixer/system headroom. A setting of less than full clockwise will yield lower system noise at the expense of mixer/system headroom. A more thorough discussion of input sensitivity follows later in this manual.

A MAINS POWER SWITCH (5)

The front panel of the CS 1000X contains a conventional on/off rocker switch. When the amplifier is plugged into a suitable power source, activating this switch should light both channel "0" array LEDs after the power-up delay sequence is completed (approximately two seconds). You should also be able to hear the output relays close (click). If the amplifier is cool, the fan should start on low-speed operation. If only one channel "0" indicator lights, then the possibility exists of an internal "fault." If neither channel "0" indicator lights, check the rear panel circuit breaker and the mains power source. It's always a good idea to check to see that the cooling fan is operational, especially on a new unit. The possibility exists that due to shipping and handling, the fan bearings may be too tight to allow low-speed fan operation. If this is the case, immediately seek professional help. The CS 1000X must have normal fan operation to provide adequate cooling for the unit. Without air flow, the amplifier will "thermal" very quickly under any signal conditions.

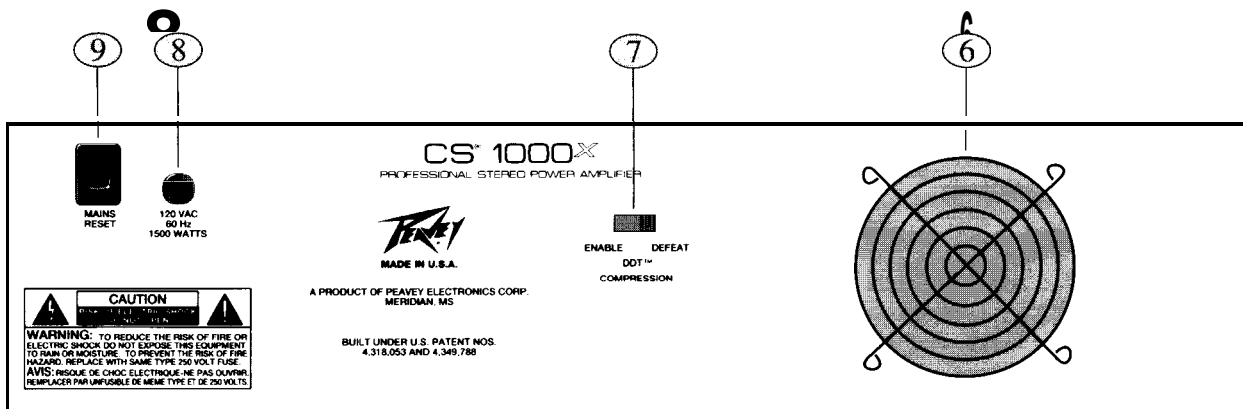

GRILLE (6)

The back panel includes the fan opening with protective grille (6), where cooling air is drawn into the amplifier. This opening should never be blocked or restricted.

DDT SWITCH (7)

This switch is used to either ENABLE or DEFEAT the DDT compressor. Defeating the DDT compressor should not be performed lightly or simply as a matter of course. Most loudspeaker systems simply cannot handle the square wave power of the CS 1000X, and defeating this valuable limit can eventually cause the speakers to be damaged.

A MAINS POWER SOURCE (120V products only) (8)

The CS 1000X is fitted with a single heavy-duty #14 AWG 3 conductor line cord and a conventional AC plug with a ground pin. It should be connected to an independent mains circuit capable of delivering at least 15 AMPS continuously. This is particularly critical for sustained high-power applications. If the socket does not have a ground pin, a suitable ground lift adaptor should be used, and the third wire grounded properly.

Never break off the ground pin on the CS 1000X or any amplifier. The use of extension cords should be avoided, but if essential, always use a three-wire type with at least a #14 AWG wire size. The use of lighter wire will severely limit the power capability of this amplifier. Always use a qualified electrician to install any necessary electrical equipment. To prevent the risk of shock or fire hazard, always be sure that the amplifier is properly grounded.

CIRCUIT BREAKER (9)

The new CS 1000X now features a circuit breaker in place of the mains fuse. This breaker is provided to limit the mains current to the associated power transformer, thereby protecting it from overheating and possible destruction due to any fault conditions in the amplifier. The trip current value has been carefully chosen to allow continuous power output performance, while still providing adequate protection for the power transformer itself. Normally the breaker should not trip; however, abnormal conditions such as a short circuit on either or both channels, or continuous operation at overload or clipping, especially into a 2-ohm load, will cause the breaker to trip. If this occurs, simply reset the breaker and correct the cause of the overload. When tripped, the button on the breaker will be extended outward nearly 1/2" and can be reset by pushing inward. A normal reset button length is about 1/4". If this "thermal"-type breaker does trip, simply pushing the button back in will reset it, after waiting a brief period of time to allow it to cool down. If the breaker trips instantly each time you attempt to reset it, then the unit should be taken to a qualified service center for repair.

The back panel of the CS 1000X features a unique "back-porch" design containing the various input and output connectors for each channel. A patch panel is also included, providing a very flexible system for use with balanced-input transformers and dual crossover networks. These features are unduplicated in any other stereo power amplifier on the market today.

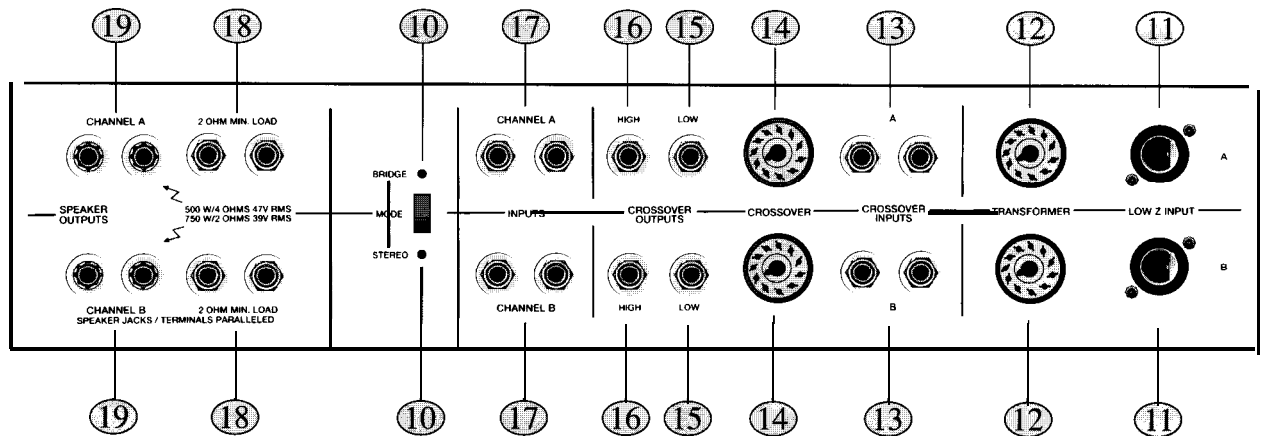

MODE SWITCH (10)

The mode switch is located on the "back-porch" next to the channel input jacks. This switch converts the CS 1000X from normal stereo mode to bridge mode. Bridge-mode operation is very popular for commercial sound distribution systems (70/100 volt lines).

WARNING: In bridge mode, the CS 1000X is capable of delivering 1000 W RMS into 8 ohms and 1500 W RMS into 4 ohms. Always be very certain that the associated loudspeaker system can handle this power level reliably. Also, be advised that in most crossover applications, accidental switching to the bridge mode could destroy the speaker system. Specific applications of the bridge mode will be covered later in this manual.

LOW-Z INPUTS (11)

Conventional three-pin, female XLR input jacks are provided, which can be used as either the channel inputs or the crossover inputs, depending upon what has been plugged into the crossover socket (14). Further, this XLR input is balanced or unbalanced, depending upon what is plugged into the transformer socket (12). When the (PL-2) line-balancing transformer is used in socket (12), this XLR input becomes fully TRANSFORMER-BALANCED, with pin #3 as the positive input and pin #2 as the negative input. When a blank plug (PL-1) is inserted in socket (12), this XLR input becomes unbalanced, with pin #3 as positive input and pin #2 as ground. If a PL-MODULE ELECTRONIC CROSSOVER is plugged into socket (14), the XLR input system drives the crossover, but if a blank plug (PL- 1) is inserted in socket (15), the XLR input system is connected directly to the channel power amp input.

TRANSFORMER RECEPTACLES (12)

These receptacles only receive the optional (PL-2) line-balancing transformer. When conditions exist that demand the usage of a TRANSFORMER-BALANCED XLR at the input of a power amp channel or at the input of the PL-MODULE ELECTRONIC CROSSOVER when BIAMPING, the (PL-2) transformer must be inserted here. Otherwise a blank plug (PL-1) is inserted in this socket.

CROSSOVER INPUTS (13)

These are the HIGH-Z INPUTS when an ELECTRONIC CROSSOVER module is installed. Two parallel input jacks are provided at this point, allowing flexible Y-cord capability. The output of the LOW-Z XLR input circuitry is always connected to these inputs, which allow the LOW-Z INPUT to be used as the ELECTRONIC CROSSOVER input if desired. These inputs can then be used as FULL-RANGE outputs for additional patching capability.

CROSSOVER MODULE RECEPTACLE (14)

This receptacle may only receive a plug-in PL-MODULE ELECTRONIC CROSSOVER. PL-MODULES are optional accessories and are available in many different crossover frequencies. Some modules contain special equalization and padding for a particular Peavey speaker enclosure. Always be sure to select the correct module for your speaker system. Other special-purpose modules are also available for use with this receptacle. This receptacle supplies both the input and output patch facilities as well as the power supply “feeds” for these active electronic devices.

CROSSOVER LOW OUTPUT (15)

This jack supplies the crossed-over low-frequency output from the installed PL-MODULE ELECTRONIC CROSSOVER. This output must be patched to the appropriate power amp input jack to “create” an operational biamp system. On some special-purpose modules, this output jack is not used.

CROSSOVER HIGH OUTPUT (16)

This jack supplies the crossed-over high-frequency output from the installed PL-MODULE ELECTRONIC CROSSOVER. This output must also be patched to the appropriate power amp input jack to create an operational biamp system.

POWER AMPLIFIER INPUT (17)

Two parallel input jacks are provided for each channel, delivering flexible Y-cord capability. These jacks can be considered the normal power amplifier high-Z input. If a blank plug (PL-1) is inserted in the crossover accessory socket (14), the associated XLR input system is connected to these input jacks internally, permitting the XLR input (11) to be a direct power amplifier input without the use of a patch cord.

SPEAKER OUTPUTS (18) (19)

Two 1/4" jacks and 5-way binding post speaker output terminals are provided for each channel, with all the outputs from each channel in parallel. Thus, the loudspeaker connection cables can be terminated with 1/4" phone plugs, banana plugs, or stripped wires for use in the binding post terminals. For sustained high-power applications, the use of the binding post terminals is highly recommended; however, care must be exercised to assure correct speaker phasing. Regardless of what connections are used, the typical parallel speaker load should always be limited to 2 ohms per channel or 4 ohms BRIDGE mode for any application. Operation at loads of 4 ohms per channel or 8 ohms BRIDGE mode is more desirable for sustained operation applications, because the amplifier will run much cooler at this load. Operation above 4 ohms per channel and even open-circuit conditions can always be considered safe; however, sustained operation at loads below 2 ohms could result in temporary amp shutdown due to operation of the thermal limiting and/or the fault detection circuitry.

INSTALLATION AND CONNECTION

The Peavey CS 1000X Commercial Series Power Amplifier is designed for durability in commercial installations and quality of performance required in studio and home applications. The unit is a standard 19" rack-mount configuration that requires 5 1/4" rack height; it is cooled by an automatic two-speed internal fan. The front panel contains various LED indicators for the monitoring of power output, DDT activation, and thermal shutdown. Detented and calibrated input sensitivity controls and a heavy-duty mains power switch are also provided. All inputs, outputs, and patch points are on the back panel.

MAINS POWER SOURCE

If possible, each amplifier should be connected to separate mains circuits capable of delivering at least 15 amps continuously. This is most critical for sustained high-power applications into 2 ohms per channel. For lesser loadings, it is possible to use two amplifiers per mains circuit, each having a 20-amp capability. Never break off the ground pin on the CS 1000X. Always use a qualified electrician to install any necessary electrical equipment. To prevent the risk of shock or fire hazard, always check to see that the amplifiers are properly grounded.

INDUSTRIAL AND COMMERCIAL INSTALLATIONS

For commercial and other installations where sustained high-power operation is required, the amplifiers should be mounted in a standard 19" rack. It is not necessary to leave a rack space between each amplifier in the stack, since the fan pulls air in from the rear and exhausts the hot air out of the front. An adequate cool air supply must be provided for the amplifiers when rack-mounted. The internal fan must have a source of air that is not preheated by other equipment. The amplifier will start up in low-speed fan operation and will normally stay at low-speed operation unless sustained high-power operating levels occur. As the amplifier heat sinks heat up, the automatic thermal-sensing circuitry will cause high-speed operation to occur. Depending upon signal conditions and amplifier loading, high-speed fan operation may continue, or the fan may cycle continuously between high and low. This situation is quite normal. If cooling is inadequate due to preheated air, or a reduction of air flow occurs due to blockage of the inlet or outlet ports, or if the amplifier is severely overloaded or short-circuited, the internal thermal-sensing system may cause temporary shutdown of that particular channel. Depending upon the availability of cool air, operation should be restored in that channel relatively quickly. In any case, corrective action should be taken to determine the cause of the thermal shutdown. If the amplifier is not severely overloaded or short-circuited, and air flow is normal in the amplifier, steps should be taken to provide a cooler environment for all the amplifiers. As a general rule, the cooler electronic equipment is operated, the longer its useful service life will be.

PORTABLE RACK-MOUNT APPLICATIONS

Due to the weight of the CS 1000X, we highly recommend that some additional support be provided at the back panel of the amplifier whenever units are installed in a portable rack-mount configuration. Two 1/4-20 allen-head bolts have been provided at the rear of the CS 1000X for this purpose. These bolts should be attached to a suitable bracketing arrangement to provide this additional support. Also, two guards have been provided on the rear panel of the CS 1000X to protect connectors and PL cans, and to provide a means for routing cables.

CAUTION: THESE ARE NOT HANDLES, AND THEY SHOULD NEVER BE USED TO LIFT THE AMPLIFIER!

STUDIO INSTALLATION

In most low- to medium-power applications, the power amplifier can be mounted in any configuration. It is desirable that, if at all possible, the power amp be located at the top of an equipment stack. This will prevent possible overheating of sensitive equipment by the hot air rising from the power amplifier. As a general rule, most home and studio requirements will never cause high-speed fan operation. If it does, however, this may indicate that you have not taken the necessary steps to provide adequate cooling. Remember, closed up in a cabinet, the CS 1000X will have severe cooling problems, even when operated at low power levels. Inadvertent short circuit or sustained overload usage could also cause temporary thermal shutdown.

INPUT CONNECTIONS

The two 1/4" jacks marked channel inputs (17) are wired in parallel for ease of connecting to each channel. The dual (parallel) jacks allow daisy-chaining to additional channels. If RCA-type pin jacks are required, a suitable adaptor can be used. Shielded cables must be used to minimize hum and noise pickup. The nominal input impedance is 20 kilohms. This impedance presents a bridging load to the associated driving equipment and is compatible with the loading limits of most home stereo devices. The CS 1000X has an input sensitivity of 1.4 V RMS (+3 dBV) for rated output with the front panel sensitivity control set to full clockwise. Again, this rating is compatible with most home stereo preamps. This sensitivity rating increases as the control is turned counterclockwise. The new sensitivity rating is indicated by the setting of the calibrated sensitivity control. It is generally wise to start off with the sensitivity control at the full clockwise setting. The sensitivity control is discussed in greater detail later in this manual.

OUTPUT CONNECTIONS

Two types of output connectors are provided on the rear panel of the amplifier. Two standard 1/4" phone jacks wired in parallel (18) and one set of 5-way binding posts (19) are available on each channel. Due to the high currents at full-output power, it is recommended that #16 AWG or larger wire size be used whenever possible. For extremely long runs (30' or greater), #14 AWG should be used. Smaller wire sizes will waste power and yield less than optimum results at the speaker. We suggest that in commercial and other non-portable applications, the 5-way binding posts (18) be used instead of the 1/4" phone jacks. The binding posts are an industry standard, and matching banana plugs are available at most electronic distributors. As with any electronic equipment, proper phase of the outputs is a necessity.

OPERATION

The CS 1000X is designed for maximum ease and flexibility of operation. When the unit is installed and connected as described in the previous sections, operation is as simple as turning on the mains switch (5), turning up the sensitivity controls (4) to the full clockwise setting, and then adjusting the associated mixer or pre-amplification equipment to supply the necessary signal levels to provide the desired output level or until the front panel DDT active LED indicator shows that the amplifier is compressing. Further increases in

signal levels beyond this point will not produce any significant increase in output and may cause distortion problems.

MODES OF OPERATION

1. STEREO MODE (UNBALANCED INPUTS)

The CS 1000X is shipped from the factory with jumper plugs inserted in the transformer (12) and crossover (14) accessory sockets. These jumper plugs are necessary if the low-impedance connectors (11) are to be used as inputs for each channel. As indicated in Diagram 1, the XLR connectors are wired in an unbalanced configuration (pins 1 and 2 are ground; pin 3 is input). The unbalanced-input configuration is acceptable whenever relatively short cable runs are employed, or when the associated mixer used has a full transformer-balanced output. Under these circumstances, this configuration will usually provide adequate hum and interference rejection for most environments. Notice that the jumper plugs in the crossover accessory sockets are required to complete the signal patch to the respective power amp inputs (17). If the normal unbalanced 1/4" power amp input jacks are used instead, the jumper plugs are not necessary. It is suggested, however, that they be left in their respective sockets for possible later usage. As with all Peavey amplifiers, the CS 1000X has two power amp input jacks per channel (17), which offer considerable flexibility in hook-up possibilities. For monaural operation, the same signal is applied to both channels; the mixer output is plugged in one of the parallel input jacks in one of the channels, and a short shielded jumper cable is connected between the remaining input jack on that channel to one of the parallel input jacks on the other channel. This technique is called daisy-chaining, and can be repeated many times to patch to additional amplifier channels requiring the same signal feed.

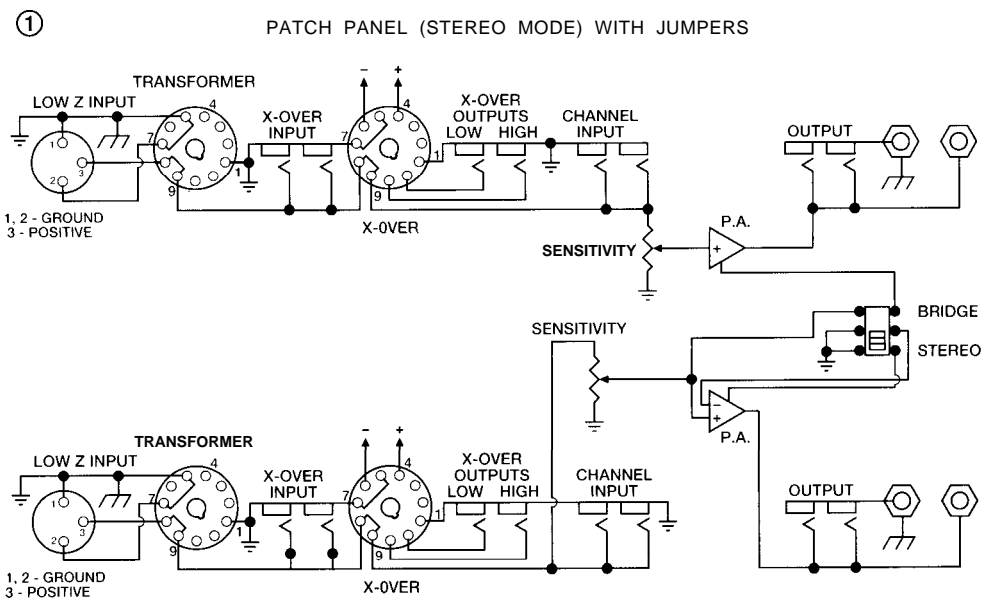

2. STEREO MODE (BALANCED INPUTS)

When conditions require the use of a balanced input at the power amplifier, the XLR connectors (11) on either or both channels can be converted to a balanced configuration by removing the jumper plug from the transformer accessory socket (12) and plugging in an input transformer module (PL-2). The Peavey model PL-2 transformer module is a nominal 1:1 turn-ratio type, resulting in unity gain. In Diagram 2, the XLR connector is now wired as a conventional balanced-type input (pin 1 is ground; pin 2 is negative; pin 3 is positive). The jumper plugs in the crossover accessory sockets are required to complete the signal patch to the respective power amp inputs (14). For balanced stereo operation, two PL-2 modules are required. For monaural operation, only one PL-2 is needed, and the inputs can be connected by placing a short shielded jumper cable between one of the power amp input jacks (17) on each channel. Thus, the XLR connector associated with the PL-2 module is the balanced-system input, and the other XLR connector is not used.

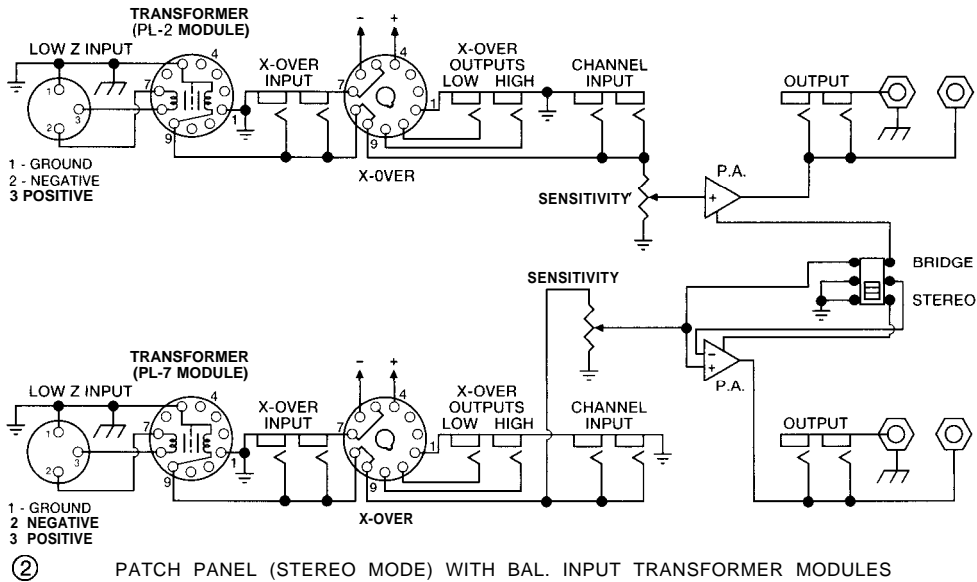

3. BIAMP STEREO MODE

The Peavey CS-1000X patch panel can also be used to biamp and/or provide special equalization capabilities for loudspeaker systems. Various electronic crossovers and special purpose modules are available in a broad range of frequencies for both Peavey and non-Peavey loudspeaker systems. More complicated systems, such as stereo biamped, triamped, or even 4-way crossover systems are possible. We suggest you contact your Authorized Peavey Dealer for details. A typical stereo biamp system will be discussed in this manual. Referring to Diagram 3, the jumper plugs in both crossover accessory sockets (14) have been replaced by two-way crossover modules. Also, notice that the PL-2 transformer modules are still in the transformer accessory sockets (12). This configuration now has the makings of a complete stereo-balanced biamp system. The only thing required is an additional stereo power amplifier, which, together with the existing dual power amp sections of the CS 1000X, makes up the four independent power amplifiers required for a stereo biamplification system. You will notice that because of the pin-out arrangements of the jumper plugs versus the crossover networks, whenever the jumper plugs are removed from the crossover accessory sockets (14), the power amplifier inputs for the respective channels are isolated (no longer connected to anything). In other words, the crossover modules and all associated connectors (as well as the PL-2 transformers and respective XLR connectors) are islands unto themselves: in this case, two islands with

③ PATCH PANEL (STEREO MODE) WITH CROSSOVER AND INPUT TRANSFORMER MODULES

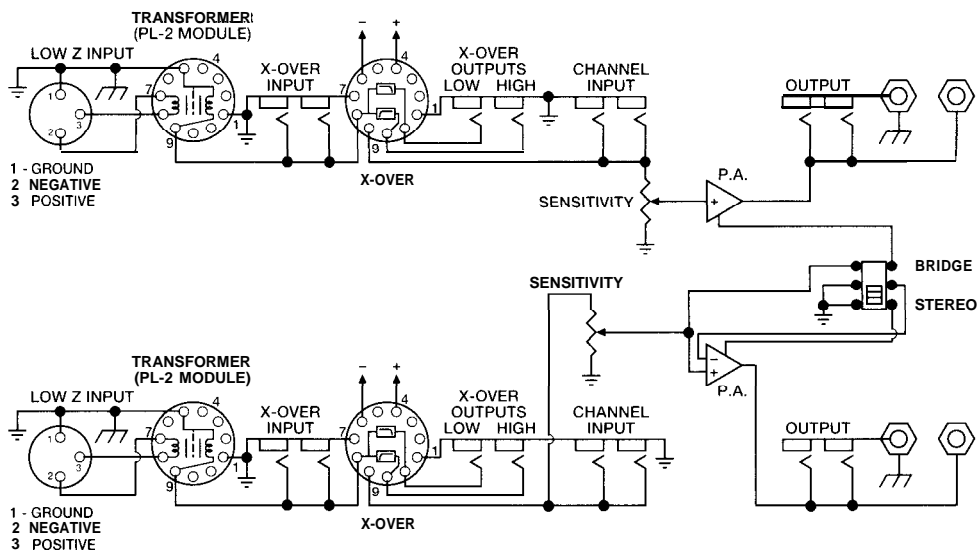

each crossover having a balanced input (11), dual (parallel) unbalanced inputs (13), an unbalanced low output (15), and an unbalanced high output (16). In order to complete the system, external patching must be accomplished between the low and high crossover outputs and the various power amp inputs using shielded patch cords. A patch diagram showing this arrangement is included at the end of this manual.

3A. BIAMP MONO MODE

Obviously, for a monaural biamp system (only one mixer feed), only one crossover module is required and only one crossover island will be used. In this case, one channel of the CS 1000X can be patched for the lows and the other channel patched for the highs, resulting in a simple, compact system with outstanding performance.

CAUTION:

Since the CS 1000X is capable of producing more than 500 watts RMS per channel into a 4-ohm load, the high-frequency components of the particular loudspeaker system must be able to handle these power levels reliably. Alternatively, use a smaller power amplifier!

4. BRIDGE MODE

Diagram 4 shows the actual arrangement for the CS 1000X patch panel in the bridge mode. Notice that the jumper plugs are inserted in the transformer (12) and crossover (14) accessory sockets of Island A. These jumper plugs cause the XLR connector of this island to be wired in the unbalanced configuration (as in Diagram 1) and complete the connection to the Channel A power amp input jacks (which are now the only active inputs). The Channel A sensitivity control now determines the sensitivity of the bridge-mode amplifier. The Channel B input jacks and sensitivity control serve no purpose in this mode, and are actually electronically removed from the circuit. Both sets of parallel 1/4" output phone jacks are also not normally used in the bridge mode. Remember, the 4-ohm minimum load must be connected between the red binding posts. If individual loads were connected to each output (as in normal stereo applications) when the bridge mode is selected, Channel A would supply a normal in-phase signal to its respective load, but Channel B would supply an abnormal out-of-phase signal to its respective load, and both of these signals would contain Channel A source material (Channel B source material, if present, would be defeated). This is a potentially dangerous situation, especially if the individual channels are being used to supply high and low signals in a typical biamp configuration. Obviously, the speaker components on Channel B would no longer be supplied their intended signal but an out-of-phase version of the Channel A signal, which could easily destroy the

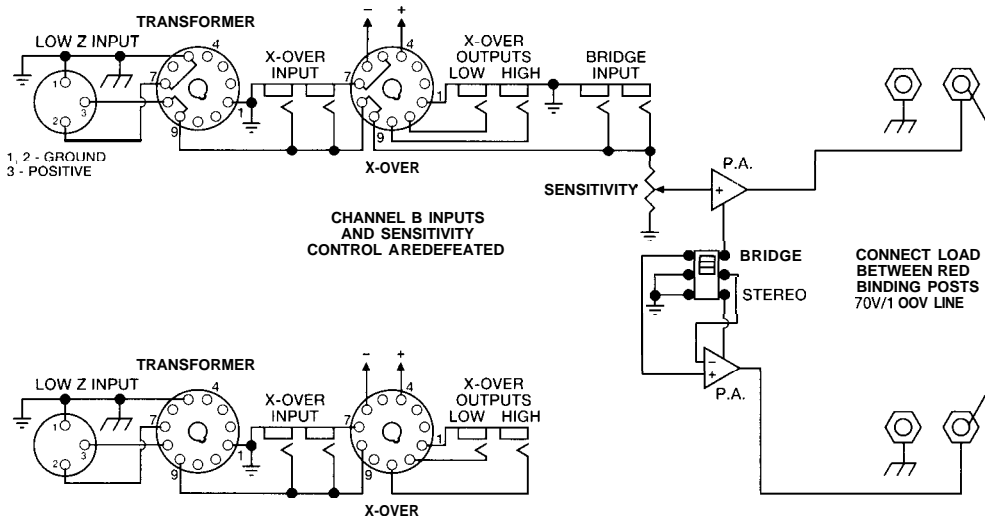

④

PATCH PANEL (BRIDGE MODE) WITH JUMPERS

associated loudspeaker components. To help prevent this, whenever the bridge mode is selected, the standby ("0") LED and the LED array itself on Channel B is defeated (off), just as if there was some kind of a fault condition present on Channel B. This provides a positive indication that the CS 1000X is no longer in the stereo mode.

INPUT SENSITIVITY CONTROLS

The input sensitivity rating of a power amplifier is the RMS voltage level required at the input to produce full-rated power into the rated load at the output. This voltage then becomes the level at which the associated mixer must operate in order to drive the amplifier to full output. The CS 1000X sensitivity controls are calibrated in decibel volt values rather than RMS voltage (usually listed in typical mixer specs), and as such are more useful, since most contemporary mixers employ LED arrays to indicate mixer output levels and are calibrated in decibel volts. Knowing the power amplifier sensitivity rating in decibel volts will allow the mixer operator to know the status of the power amplifier by noting which LED on the mixer is peaking. Obviously, the LED labeled the same or closest to the sensitivity rating of the power amplifier will indicate full power output of the system. Operation at levels above this rating will cause the power amplifier to clip (produce distortion) unless the associated amplifier has a compressor/limiter to minimize this distortion. Such a system, called DDT (U.S. Patent #4,318,053), is included in the CS 1000X, and the advantages should be obvious. Without DDT, the sound engineer must "ride gain" on the mixer or employ an outboard limiter in order to prevent amp clipping. With DDT the sound man can relax more and enjoy the "ride." For maximum mixer headroom (which in turn really is maximum compression range), the input sensitivity control should be set at the maximum clockwise setting. This is always the best setting to start with. If, however, the amplifier is used in a small club, church, or studio application where the full-output capability of the power amplifier is seldom needed, or there is no need for large amounts of headroom capability, the full-clockwise setting may not be the wisest choice. Then too, such applications often require low system noise. In this case, it is possible to reduce the overall system noise at the expense of headroom capability by increasing the power amplifier sensitivity as in the following example: if, instead of a sensitivity rating of +3 dB V, we adjust the CS 1000X to a rating of +12dB V, overall system noise will be improved by 9 dB, and the system headroom will decrease 9 dB.

DDT™ COMPRESSION

The CS 1000X is a compact and powerful amplifier that features a new type of dynamic compression. This compression system enables the user to maximize the performance of the amplifier/speaker combination. We have determined through much research that the compression circuitry should prevent the power amplifier from running out of headroom (clipping) and should be as simple to operate as possible to avoid undue complication for the user. This compression system is activated by our exclusive DDT compression circuitry, which senses conditions that might overload the amplifier and activates compression when clipping is imminent. In other words, compression takes place whenever signal conditions exist that prevent the amplifiers from faithfully reproducing the input signal. In this case, threshold is clipping itself, and no specific threshold control is provided. This technique effectively utilizes every precious watt available from the power amplifier. Techniques using external compressors/limiters are usually less effective, severely limit output power levels and require additional controls, and add complexity to an already complicated system. The DDT system is an automatic, hands-off approach to the problem of amp clipping. Because of the dynamics of music and vocals, it is quite common to activate the DDT compression circuitry almost constantly during a high-level performance, since this is what it was designed to do: i.e., to maximize the dynamics available from the amplifier within its power-output capabilities regardless of power supply/AC line voltage variations and load impedance selection. Defeating the DDT compression should be very carefully considered before one just "flips the switch." Most loudspeaker systems simply cannot handle the square wave power of the CS 1000X, and defeating the DDT system opens up the door for severe clipping!

Often studio engineers feel the need to defeat the DDT compressor, for fear it might color the sound in studio listening. The DDT compressor is only activated when clipping is imminent. Until this occurs, it's simply a passive friend. The only reason the defeat switch is there in the first place is to allow check-out technicians to evaluate the power amplifier at clipping. Valuable performance information, such as power-supply ripple and regulation, can only be assessed when an amplifier is allowed to clip.

THERMAL SYSTEM

The CS 1000X has a unique thermal system that employs a tunnel-type heat sink design to provide maximum cooling for the 24 power transistors (12 for each channel). A single 100 CFM fan mounted on the back panel of the unit provides an almost unrestricted airflow through the tunnel to provide the lowest possible operating temperature for the power devices. This approach is so efficient that even continuous operation into 2 ohms will not cause a thermal shutdown unless the ambient air temperature is considerably higher than normal (above 40° C). Under normal intermittent applications, low-speed fan operation will provide adequate cooling. Since the CS 1000X is a two-channel amplifier, but only one fan is employed, the fan circuitry is an independent system, separately fused internally. You will notice that the heat sink components are divided horizontally. The lower half contains Channel A output transistors, while the upper half belongs to Channel B. The fan provides equal cooling for both channels. Each channel has separate built-in thermal sensors and fault logic circuitry. If one channel's heat sink reaches an operating temperature of 60°C, its logic will cause high-speed fan operation irrespective of the other channel's operating temperature. In other words, either channel's heating will control the fan speed. Under normal continuous usage at full-rated power output into the rated load, the thermal logic system will continuously monitor heat sink temperatures and will automatically select the fan speed required to maintain safe operating limits for the power transistors.

HIGH TEMPERATURE LIMITS

Because of the very efficient design of the CS 1000X heat tunnel dissipation system, thermal shutdown conditions will almost never occur unless there is truly an external fault. For continuous operation, the CS 1000X requires a source of cool air. As an added help in locating mismatched or shorted speakers, the DDT active LED is a powerful tool. If this LED flashes continuously at relatively low-output power levels (indicated by low-power readings on the LED array), it is almost a sure sign that the amplifier loading impedance is too low in value, or that there might be a short circuit. Remember, usually the power LED array should reach 100% before the DDT system is activated on any particular channel. The CS 1000X also has a fail-safe thermal mechanism built into the unit. If either channel's thermal logic system should fail to cause thermal shutdown in that channel or if the fan itself should fail, this fail-safe system will shut down the entire amplifier, just as if you had turned off the power switch. This is just one more protection that Peavey has incorporated into this unique amplifier as a backup system. If this should ever occur, immediately seek professional help at an authorized Peavey service center.

PASSIVE CROSSOVER

The purpose of a traditional high-level passive crossover found inside most speaker systems is to separate the low-frequency material from the program and feed it to the woofer (low-frequency driver), and to separate the high-frequency material from the program and feed it to the tweeter (high-frequency driver). This crossover is connected between a power amplifier and the speakers, and, as its name implies, is made up entirely of passive components (no transistors or tubes). Such a system is usually referred to as "full-range," which simply means that the power amplifier must handle the full range of frequencies. There are many good reasons for using a bi-amplified professional system as opposed to a full-range system. One reason is that the biamp system will provide more headroom with the same power amplifier complement than that of the full-range system.

The term headroom deserves some consideration. Program material (music or speech) is made up of many different frequencies and their harmonics. Most music, especially contemporary rock music, is bass-heavy. That is, the low-frequency material contains much more energy than the high-frequency material. If both high- and low-frequency material, such as voice and bass guitar, are present in a full-range system, the high-energy bass frequencies can use up most of the power available from the power amplifier, leaving little (or none) for the high frequencies. The result usually is severe clipping (distortion) of the high-frequency material. In a biamplified system, the high-frequency material is routed to its own power amplifier (and associated loudspeaker), which avoids the clipping problem. This results in an effective increase in system headroom that is greater than that which is obtained by simply using a second power amplifier/speaker combination in full-range operation. To biamp, then, some type of active crossover is employed in the mixer feed to separate the low- and high-frequency material, which is then patched to separate power amplifiers to drive separate loudspeaker components. Such a system is easily accomplished with the Peavey CS 1000X power amplifier patch panel and associated CS Series plug-in active crossover modules.

The Peavey DDT compression system adds a totally new dimension to the typical biamped system. Each power amplifier channel now has its own Distortion Detection Technique circuitry, and each is completely independent. When signal conditions exist that could cause clipping in the low-frequency power amp channel(s), the DDT system will simply limit that portion of the total biamp system. This will in no way affect the high-frequency portion of the biamp system, and it is free to increase in level until conditions exist that could cause clipping in that particular power amp channel(s). At that point, the DDT system will limit the high-frequency portion of the system. This is a very effective two-level compression system and will yield sound pressure levels unmatched by conventional broad-band compression techniques.

BIAMP SYSTEM NOTES

1. A biamp configuration is only possible with loudspeaker systems that provide access to the individual speaker components, bypassing the built-in passive crossover (most Peavey systems offer biamp high and low switching jacks on the back panel).
2. The crossover module used must have the proper characteristics to match the particular loudspeaker system. Of greatest importance is the crossover frequency. Peavey offers a variety of plug-in crossover modules that are specifically designed to match the various loudspeakers in the Peavey product line. These crossovers have the correct crossover frequency, high-frequency pad, and equalization for the particular loudspeaker, resulting in system performance with a very flat frequency response. Also available are general purpose crossover modules at various frequencies from 100 to 5000 Hz for non-Peavey loudspeaker systems.
3. The outputs of the crossover modules (both high and low) can drive several power amp inputs. The parallel input jacks can be used to daisy-chain to additional power amps for an expanded system on either the low- or high-frequency system (or both). Remember, the components in most Peavey biampable speaker systems are 8 ohms. All Peavey CSX series power amplifiers are now rated at 2 ohms. This means that the allowable maximum number of components connected to any one particular power amplifier channel is four (four horns, four woofers). If additional components are required in larger systems, more power amp channels are needed. Often experienced sound technicians limit the maximum number of components to three per power amp channel. This practice allows the power amplifiers to run much cooler and creates a system that is less likely to shut down thermally in a high-temperature environment!
4. The PL-2 transformer module can be removed and the jumper reinstalled in any particular crossover island if a balanced input is not desired or required for the crossover module. In this case, the associated XLR connector (11) is now unbalanced as per previous discussion. If desired, the parallel unbalanced phone jack inputs (13) may be used to supply signal to the crossover module. In addition, whenever the XLR connector on a particular crossover island is used (either balanced or

unbalanced), the crossover input jacks (13) can be used to patch out full-range signals to other amplifier/speaker systems that are operating in full range or other biamped systems that require different crossovers.

A

5. Care must be taken never to remove or replace a crossover module with the CS 1000X power switch on. The complex circuitry used in the crossover modules receives bipolar power through the socket, and removal or replacement could cause severe transients that can destroy the loudspeaker system. Always turn off the CS 1000X first. As an added feature, the bipolar power for the crossover islands can be supplied from either channel of the CS 1000X. Thus, if one channel should shut down for any reason, the redundancy of the system will maintain operation of the crossovers.
6. The individual sensitivity controls on each channel play a very important role in the use of the crossover modules. As such, they represent a signal loss when they are operated at another setting other than full clockwise (maximum sensitivity). Biamped speaker systems usually require less signal level for the high-frequency components because they are generally more efficient. Consequently, a system balance can be achieved by reducing the high-pass level. This is particularly important on non-Peavey loudspeakers where the PL-500, PL-800 or PL- 1200 crossover modules must be used. These modules are referred to as “no pad and equalization” types. As such, there is no reduction in high-pass level. Consequently, the pad must be accomplished using the high-pass channel sensitivity control. The amount of pad required is always the difference between the efficiency ratings of the high and low speaker components. Whenever Peavey loudspeakers are operated using the special crossovers, the sensitivity controls should be set at full-clockwise settings (maximum sensitivity) to provide maximum system headroom, since the correct pad and equalization is already provided in the crossover module itself.

BRIDGE MODE NOTES

1. The bridge mode on stereo amplifiers is often misunderstood as to actual operation and usage. In basic terms, when a two-channel amplifier is operated in the bridge mode, it is converted to a single-channel unit with a power rating equal to the sum of both channels’ continuous power ratings, at a load rating of twice that of the single-channel ratings. For the CS1000X, the bridge ratings are now 1000 W RMS into 8 ohms and 1500 W RMS into 4 ohms (minimum load). Bridge-mode operation is accomplished by placing the mode switch (10) in the bridge position, connecting the load between the red binding posts of each channel, and using Channel A as the input channel. All the input functions of Channel B are defeated. What actually happens from a technical standpoint is that Channel B is supplied an input signal that is equal in level but is 180 degrees out of phase from that of the Channel A input signal (i.e., when Channel A’s signal is positive, Channel B’s signal is negative, and vice versa). Thus, the load (which is connected between the channel outputs) sees the sum of the output voltages of both channels (which is then twice that of the single channel), and this load must be 4 ohms or greater.
2. For proper bridge-mode operation, both wires of the output must “float” above ground. If either wire becomes grounded, this will present a short circuit to the associated channel of the CS 1000X. As an aid in determining the condition of the distribution system, the DDT activation LEDs on both channels are operational when the bridge mode is selected. Whenever the CS 1000X reaches full-power output, both DDT activation LEDs should flash simultaneously, indicating that DDT compression is taking place in both channels. This is a normal indication, since in bridge mode with normal loading, both channels should reach full power simultaneously. If the DDT activation LED on one channel flashes at a much lower signal level than that of the other channel, this indicates that the bridge loading is not balanced, and that one leg may have become shorted to ground. In this case, steps should be taken to locate the problem and clear it. If both LEDs flash at relatively low-output power levels, this indicates that the total bridge loading is too low in value or possibly

shorted across itself. Remember, just as in the stereo mode, the power LED array (Channel A) should reach 100% indication before the DDT system is activated on both channels.

3. The jumper plug in the transformer accessory socket (12) of channel A island can be replaced with a PL-2 transformer module. This will convert the XLR connector on Island A to balanced operation and provide a balanced input for the bridged CS 1000X.
4. The jumper plug in the crossover accessory socket (14) of the Channel A island can be replaced with a crossover or other special-purpose plug-in module. As per previous discussion, the associated bridge power amp input jacks (17) are now isolated, and signals must be patched to this bridge input to complete the circuit. Obviously, in bridge mode, the CS 1000X is only a one-channel amp. Consequently, to biamp, additional power amplifier channels must be available. Again, a word of caution concerning the power-handling capability of the associated loudspeaker components: Unless the components are part of an array connected in some series/parallel arrangement to distribute the power, biamping with the CS 1000X in bridge mode (1500 watts) should be avoided.
5. You should notice from Diagram 4 that crossover island B is completely isolated whenever bridge mode is selected, and it is normally not used. We leave its use to your imagination....

A Attention Mr. Service Technician:

If the time should ever come for you to service this power amplifier, it is important that you have the proper information on unit disassembly in order to gain access to the heat tube itself and all the associated circuitry. Our Service Department is ready to help you with any additional instructions on the correct service parts.

A Warning:

There are no user-serviceable parts or functions inside the amplifier. Disassembly should only be attempted by a qualified Peavey service technician, and only after the amplifier has been disconnected from the mains power source.

A Warning:

Voltage levels inside this amplifier could cause severe bodily harm. Always disconnect unit from mains power source and discharge major electrolytic capacitors before attempting to service. Additionally, the mains power source is switched by a mains triac, which is controlled by the front panel rocker switch. Mains power voltage is always present at this triac even with the switch off.

CS-1000X PATCH DIAGRAMS

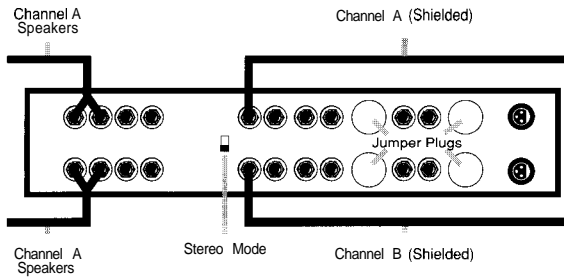

PATCH DIAGRAM 1
Stereo Operation
Unbalanced High Z Inputs
(Typical Home Stereo)

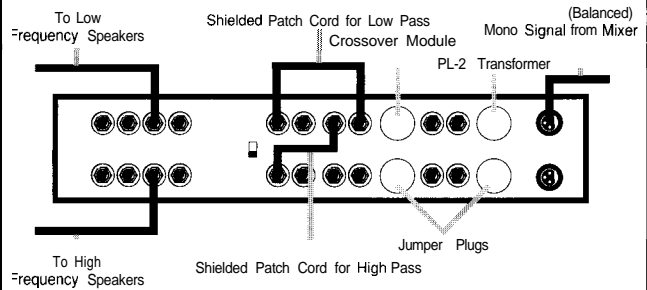

PATCH DIAGRAM 5
Biamp Operation
Balanced Low Z Input
(Monaural Signal)

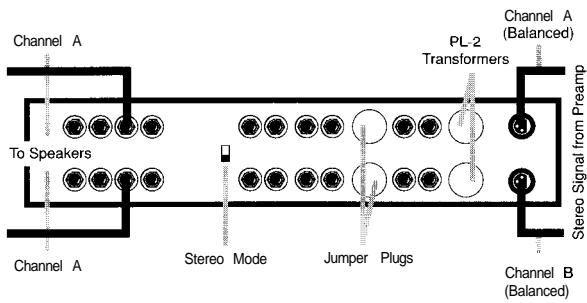

PATCH DIAGRAM 2
Stereo Operation
Balanced Low Z Inputs

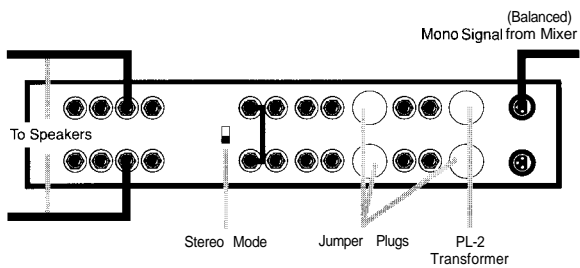

PATCH DIAGRAM 3
Monaural Operation
Balanced Low Z Inputs
(Jumped Inputs)

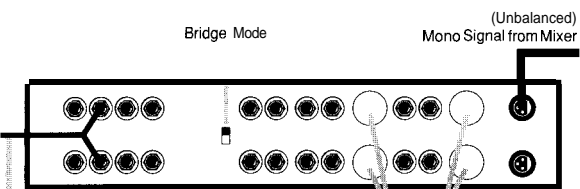

8 Ohm Speaker Load
Connected Between Red Binding Posts

PATCH DIAGRAM 4
Bridge Mode Operation
Unbalanced Low Z Inputs
(Pin #3 Input)

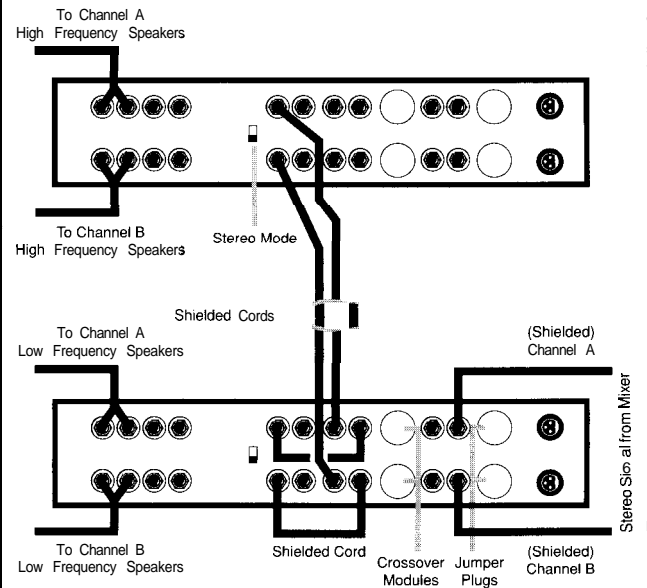

PATCH DIAGRAM 6
Biamp Operation
Unbalanced High Z Inputs
(Stereo Signal)

THIS LIMITED WARRANTY VALID ONLY WHEN PURCHASED AND REGISTERED IN THE UNITED STATES OR CANADA. ALL EXPORTED PRODUCTS ARE SUBJECT TO WARRANTY AND SERVICES TO BE SPECIFIED AND PROVIDED BY THE AUTHORIZED DISTRIBUTOR FOR EACH COUNTRY.

Ces clauses de garantie ne sont valables qu'aux Etats-Unis et au Canada. Dans tous les autres pays, les clauses de garantie et de maintenance sont fixées par le distributeur national et assurées par lui selon la législation en vigueur.

Diese Garantie ist nur in den USA und Kanada gültig. Alle Export-Produkte sind der Garantie und dem Service des Importeurs des jeweiligen Landes unterworfen. Esta garantía es válida solamente cuando el producto es comprado en E.U. continentales o en Canada. Todos los productos que sean comprados en el extranjero, están sujetos a las garantías y servicio que cada distribuidor autorizado determine y ofrezca en los diferentes países.

PEAVEY ONE-YEAR LIMITED WARRANTY/REMEDY

PEAVEY ELECTRONICS CORPORATION ("PEAVEY") warrants this product, EXCEPT for covers, footswitches, patchcords, tubes and meters, to be free from defects in material and workmanship for a period of one (1) year from date of purchase, PROVIDED, however, that this limited warranty is extended only to the original retail purchaser and is subject to the conditions, exclusions, and limitations hereinafter set forth:

PEAVEY 90-DAY LIMITED WARRANTY ON TUBES AND METERS

If this product contains tubes or meters, Peavey warrants the tubes or meters contained in the product to be free from defects in material and workmanship for a period of ninety (90) days from date of purchase: PROVIDED, however, that this limited warranty is extended only to the original retail purchaser and is also subject to the conditions, exclusions, and limitations hereinafter set forth.

CONDITIONS, EXCLUSIONS, AND LIMITATIONS OF LIMITED WARRANTIES

These limited warranties shall be void and of no effect, if:

- a. The first purchase of the product is for the purpose of resale; or
- b. The original retail purchase is not made from an AUTHORIZED PEAVEY DEALER; or
- c. The product has been damaged by accident or unreasonable use, neglect, improper service or maintenance, or other causes not arising out of defects in material or workmanship; or
- d. The serial number affixed to the product is altered, defaced, or removed.

In the event of a defect in material and/or workmanship covered by this limited warranty, Peavey will:

- a. In the case of tubes or meters, replace the defective component without charge.
- b. In other covered cases (i.e., cases involving anything other than covers, footswitches, patchcords, tubes or meters), repair the defect in material or workmanship or replace the product, at Peavey's option; and provided, however, that, in any case, all costs of shipping, if necessary, are paid by you, the purchaser.

THE WARRANTY REGISTRATION CARD SHOULD BE ACCURATELY COMPLETED AND MAILED TO AND RECEIVED BY PEAVEY WITHIN FOURTEEN (14) DAYS FROM THE DATE OF YOUR PURCHASE.

In order to obtain service under these warranties, you must:

- a. Bring the defective item to any PEAVEY AUTHORIZED DEALER or AUTHORIZED PEAVEY SERVICE CENTER and present therewith the ORIGINAL PROOF OF PURCHASE supplied to you by the AUTHORIZED PEAVEY DEALER in connection with your purchase from him of this product.

If the DEALER or SERVICE CENTER is unable to provide the necessary warranty service you will be directed to the nearest other PEAVEY AUTHORIZED DEALER or AUTHORIZED PEAVEY SERVICE CENTER which can provide such service.

OR

- b. Ship the defective item, prepaid, to:

PEAVEY ELECTRONICS CORPORATION
International Service Center
326 Hwy. 11& 80 East
MERIDIAN, MS 39301

including therewith a complete, detailed description of the problem, together with a legible copy of the original PROOF OF PURCHASE and a complete return address. Upon Peavey's receipt of these items:

If the defect is remedial under these limited warranties and the other terms and conditions expressed herein have been complied with, Peavey will provide the necessary warranty service to repair or replace the product and will return it, FREIGHT COLLECT, to you, the purchaser.

Peavey's liability to the purchaser for damages from any cause whatsoever and regardless of the form of action, including negligence, is limited to the actual damages up to the greater of \$500.00 or an amount equal to the purchase price of the product that caused the damage or that is the subject of or is directly related to the cause of action. Such purchase price will be that in effect for the specific product when the cause of action arose. This limitation of liability will not apply to claims for personal injury or damage to real property or tangible personal property allegedly caused by Peavey's negligence. Peavey does not assume liability for personal injury or property damage arising out of or caused by a non-Peavey alteration or attachment, nor does Peavey assume any responsibility for damage to interconnected non-Peavey equipment that may result from the normal functioning and maintenance of the Peavey equipment.

UNDER NO CIRCUMSTANCES WILL PEAVEY BE LIABLE FOR ANY LOST PROFITS, LOST SAVINGS, ANY INCIDENTAL DAMAGES, OR ANY CONSEQUENTIAL DAMAGES ARISING OUT OF THE USE OR INABILITY TO USE THE PRODUCT, EVEN IF PEAVEY HAS BEEN ADVISED OF THE POSSIBILITY OF SUCH DAMAGES.

THESE LIMITED WARRANTIES ARE IN LIEU OF ANY AND ALL WARRANTIES, EXPRESSED OR IMPLIED, INCLUDING, BUT NOT LIMITED TO, THE IMPLIED WARRANTIES OF MERCHANTABILITY AND FITNESS FOR A PARTICULAR USE; PROVIDED, HOWEVER, THAT IF THE OTHER TERMS AND CONDITIONS NECESSARY TO THE EXISTENCE OF THE EXPRESSED, LIMITED WARRANTIES, AS HEREINABOVE STATED, HAVE BEEN COMPLIED WITH, IMPLIED WARRANTIES ARE NOT DISCLAIMED DURING THE APPLICABLE ONE-YEAR OR NINETY-DAY PERIOD FROM DATE OF PURCHASE OF THIS PRODUCT.

SOME STATES DO NOT ALLOW LIMITATION ON HOW LONG AN IMPLIED WARRANTY LASTS, OR THE EXCLUSION OR LIMITATION OF INCIDENTAL OR CONSEQUENTIAL DAMAGES, SO THE ABOVE LIMITATIONS OR EXCLUSIONS MAY NOT APPLY TO YOU. THESE LIMITED WARRANTIES GIVE YOU SPECIFIC LEGAL RIGHTS, AND YOU MAY ALSO HAVE OTHER RIGHTS WHICH MAY VARY FROM STATE TO STATE.

THESE LIMITED WARRANTIES ARE THE ONLY EXPRESSED WARRANTIES ON THIS PRODUCT, AND NO OTHER STATEMENT, REPRESENTATION, WARRANTY, OR AGREEMENT BY ANY PERSON SHALL BE VALID OR BINDING UPON PEAVEY.

In the event of any modification or disclaimer of expressed or implied warranties, or any limitation of remedies, contained herein conflicts with applicable law, then such modification, disclaimer or limitation, as the case may be, shall be deemed to be modified to the extent necessary to comply with such law.

Your remedies for breach of these warranties are limited to those remedies provided herein and Peavey Electronics Corporation gives this limited warranty only with respect to equipment purchased in the United States of America.

INSTRUCTIONS — WARRANTY REGISTRATION CARD

1. Mail the completed WARRANTY REGISTRATION CARD to:

PEAVEY ELECTRONICS CORPORATION
POST OFFICE BOX 2898
MERIDIAN, MISSISSIPPI 39302-2898

- a. Keep the PROOF OF PURCHASE. In the event warranty service is required during the warranty period, you will need this document. There will be no identification card issued by Peavey Electronics Corporation.
2. **IMPORTANCE OF WARRANTY REGISTRATION CARDS AND NOTIFICATION OF CHANGES OF ADDRESSES:**
 - a. Completion and mailing of WARRANTY REGISTRATION CARDS—Should notification become necessary for any condition that may require correction, the REGISTRATION CARD will help ensure that you are contacted and properly notified.
 - b. Notice of address changes — If you move from the address shown on the WARRANTY REGISTRATION CARD, you should notify Peavey of the change of address so as to facilitate your receipt of any bulletins or other forms of notification which may become necessary in connection with any condition that may require dissemination of information or correction.
3. You may contact Peavey directly by telephoning (601) 483-5365.

IMPORTANT SAFETY INSTRUCTIONS

WARNING: When using electric products, basic cautions should always be followed, including the following.

1. Read all safety and operating instructions before using this product.
2. All safety and operating instructions should be retained for future reference.
3. Obey all cautions in the operating instructions and on the back of the unit
4. All operating instructions should be followed.
5. This product should not be used near water, i.e., a bathtub, sink, swimming pool, wet basement, etc
6. This product should be located so that its position does not interfere with its proper ventilation. It should not be placed flat against a wall or placed in a built-in enclosure that will impede the flow of cooling air.
7. This product should not be placed near a source of heat such as a stove, radiator, or another heat producing amplifier.
8. Connect only to a power supply of the type marked on the unit adjacent to the power supply cord.
9. Never break off the ground pin on the power supply cord. For more information on grounding, write for our free booklet "Shock Hazard and Grounding."
10. Power supply cords should always be handled carefully. Never walk or place equipment on power supply cords. Periodically check cords for cuts or signs of stress, especially at the plug and the point where the cord exits the unit.
11. The power supply cord should be unplugged when the unit is to be unused for long periods of time.
12. If this product is to be mounted in an equipment rack, rear support should be provided.
13. Metal parts can be cleaned with a damp rag. The vinyl covering used on some units can be cleaned with a damp rag or an ammonia-based household cleaner if necessary. Disconnect unit from power supply before cleaning.
14. Care should be taken so that objects do not fall and liquids are not spilled into the unit through the ventilation holes or any other openings.
15. This unit should be checked by a qualified service technician if:
 - a. The power supply cord or plug has been damaged.
 - b. Anything has fallen or been spilled into the unit.
 - c. The unit does not operate correctly.
 - d. The unit has been dropped or the enclosure damaged.
16. The user should not attempt to service this equipment. All service work should be done by a qualified service technician
17. This product should be used only with a cart or stand that is recommended by Peavey Electronics.
18. Exposure to extremely high noise levels may cause a permanent hearing loss. Individuals vary considerably in susceptibility to noise induced hearing loss, but nearly everyone will lose some hearing if exposed to sufficiently intense noise for a sufficient time. The U.S. Government's Occupational Safety and Health Administration (OSHA) has specified the following permissible noise level exposures.

Duration Per Day In Hours	Sound Level dBA, Slow Response
8	90
6	92
4	95
3	97
2	100
1 1/2	102
1	105
1/2	110
1/4 or less	115

According to OSHA, any exposure in excess of the above permissible limits could result in some hearing loss.

Ear plugs or protectors in the ear canals or over the ears must be worn when operating this amplification system in order to prevent a permanent hearing loss if exposure is in excess of the limits as set forth above. To ensure against potentially dangerous exposure to high sound pressure levels, it is recommended that all persons exposed to equipment capable of producing high sound pressure levels such as this amplification system be protected by hearing protectors while this unit is in operation.

SAVE THESE INSTRUCTIONS!



Features and specifications subject to change without notice.